

20,000 LB PLATFORM LIFT  
PLAN VIEW  
NTS

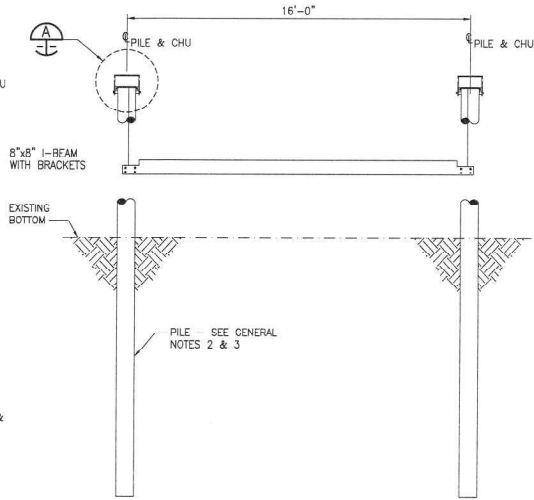

20,000 LB NO-PROFILE PLATFORM LIFT  
CROSS SECTION  
NTS

MPH	EXPOSURE (2)	WIND PRESSURE	PILE REACTIONS (5)	
			PERPENDICULAR TO CHU (3)	PARALLEL TO CHU (4)
180	C	52.1 PSF	3905#	1302#
180	D	63.0 PSF	4721#	1574#
170	C	46.4 PSF	3463#	1161#
170	D	49.7 PSF	4211#	1404#
160	C	41.1 PSF	3085#	1028#
160	D	56.2 PSF	3731#	1244#
150	C	36.2 PSF	2712#	904#
150	D	43.7 PSF	3279#	1093#
140	C	31.0 PSF	2302#	787#
140	D	36.1 PSF	2856#	959#
130	C	27.2 PSF	2037#	679#
130	D	32.8 PSF	2463#	821#
120	C	23.1 PSF	1736#	579#
120	D	28.0 PSF	2085#	689#

WIND LOADS  
NTS

- NOTES:
1. THE ALUMINUM BOAT HOIST STRUCTURE HAS BEEN DESIGNED FOR 180 MPH, RISK CATEGORY II EXPOSURE D.
  2. EXPOSURE C APPLIES TO WATER EXPOSURE FOR AN UPWIND DISTANCE BETWEEN 1,000 AND 5,000 FEET. EXPOSURE D APPLIES TO WATER EXPOSURE FOR AN UPWIND DISTANCE OF 5,000 FEET OR GREATER.
  3. WIND SPEED APPLIED TO 300 SQUARE FOOT SURFACE AREA AND DISTRIBUTED TO 4 PILES SUPPORTING THE BOAT CRADLE.
  4. WIND PRESSURE APPLIED TO 130 SQUARE FOOT SURFACE AREA AND DISTRIBUTED TO 4 PILES.
  5. PERPENDICULAR & PARALLEL PILE REACTIONS ARE NOT APPLIED SIMULTANEOUSLY.

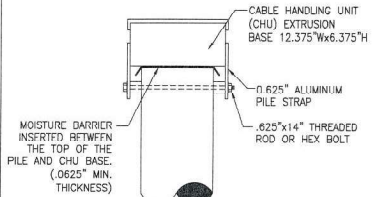

PILE CONNECTION  
DETAIL  
1 1/2" x 1" 0"

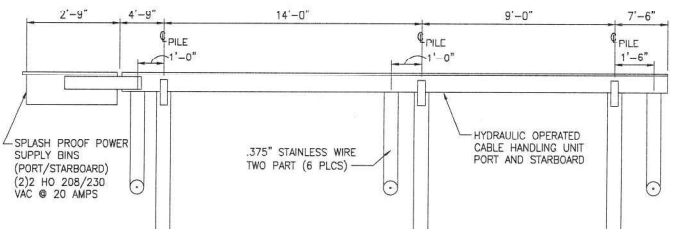

SIDE VIEW  
NTS

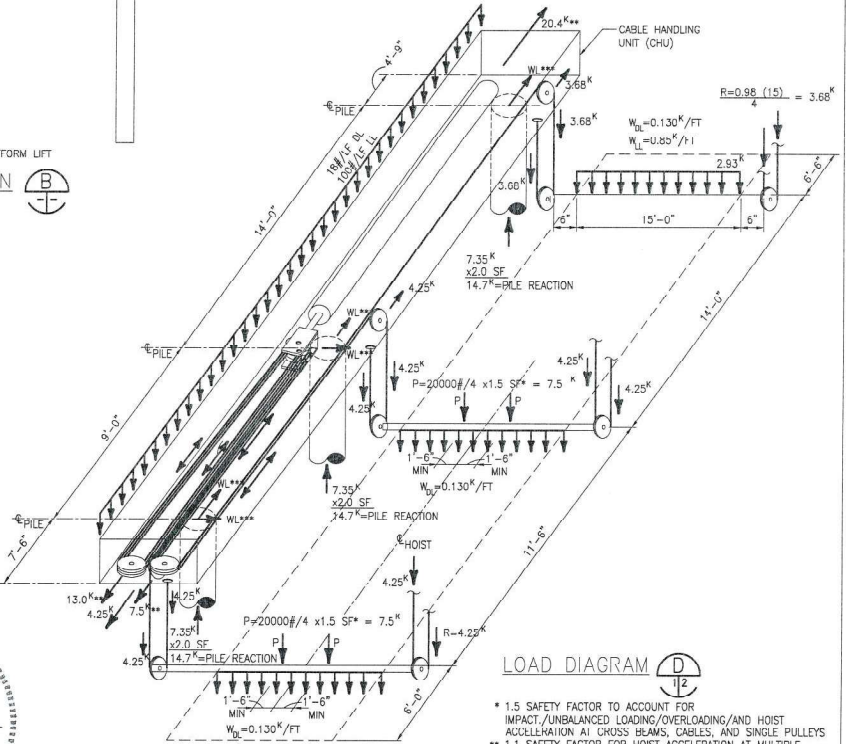

LOAD DIAGRAM  
D  
1/2

- \* 1.5 SAFETY FACTOR TO ACCOUNT FOR IMPACT/UNBALANCED LOADING/OVERLOADING/AND HOIST ACCELERATION AT CROSS BEAMS, CABLES, AND SINGLE PULLEYS
- \*\* 1.1 SAFETY FACTOR FOR HOIST ACCELERATION AT MULTIPLE CABLE PULLEYS AND PISTON
- \*\*\* WL EQUALS WINDLOAD. SEE SCHEDULE ABOVE.
- \*\*\*\* 60 PSF LIVE LOAD NOT APPLIED CONCURRENT WITH BOAT LOADS AND IS NOT A HOIST REQUIREMENT.

- GENERAL NOTES:
1. ALL HARDWARE TO BE STAINLESS STEEL UNLESS OTHERWISE NOTED.
  2. PILE MATERIAL, DIAMETER, AND DEPTH TO BE DETERMINED BY GEOTECHNICAL ENGINEER RETAINED BY THE GENERAL CONTRACTOR BASED ON LOCAL SOIL CONDITIONS.
  3. IF WOOD PILING IS USED, IT SHALL BE TREATED WITH 2.5lb CCA. IF STEEL PILING IS USED, A CATHODIC ISOLATION BARRIER SHALL BE PROVIDED BETWEEN THE STEEL PILE AND THE ALUMINUM CHU.
  4. APPROVED CONTRACTOR SHALL DETERMINE SUITABILITY OF THE EXISTING STRUCTURES AND VERIFY ALL DIMENSIONS.
  5. APPROVED CONTRACTOR IS RESPONSIBLE FOR ALL MEANS, METHODS, SEQUENCES AND PROCEDURES.
  6. LIFT DESIGNED PER FLORIDA BUILDING CODE 6TH EDITION (ZU17).
    - a) DECK LIVE LOAD = 60 PSF.
    - b) WIND LOAD—THE ALUMINUM BOAT HOIST STRUCTURE HAS BEEN DESIGNED PER ASCE 7-10 SOLID SIGN CRITERIA FOR 180 MPH, RISK CATEGORY II EXPOSURE D.
    - c) SEE TABLE FOR PILE REACTIONS FOR LATERAL WIND LOADS OF VARYING SPEEDS AND EXPOSURE CLASSIFICATIONS.
    - d) HOIST LIVE LOAD = 20,000 POUNDS



GEORGE J. LEVERETT  
FLORIDA P. E. 38336

GEORGE J. LEVERETT PE  
STRUCTURAL ENGINEERING, LLC  
3008 RIVER HALL DRIVE JACKSONVILLE FL 32217  
CERTIFICATE OF AUTHORIZATION No 28761  
(904) 923-5407

NO PROFILE BOAT LIFT		20,000 lb PLATFORM	
SCALE: AS NOTED	APPROVED BY:	DATE: 03/25/18	DRAWN BY: APR
OWNER:		REVISION:	
GEORGE J. LEVERETT, P.E. FL PE# 38336	ADDRESS:	WIND 200PL PERM	